

**CORTE 1 - FUNDOS**

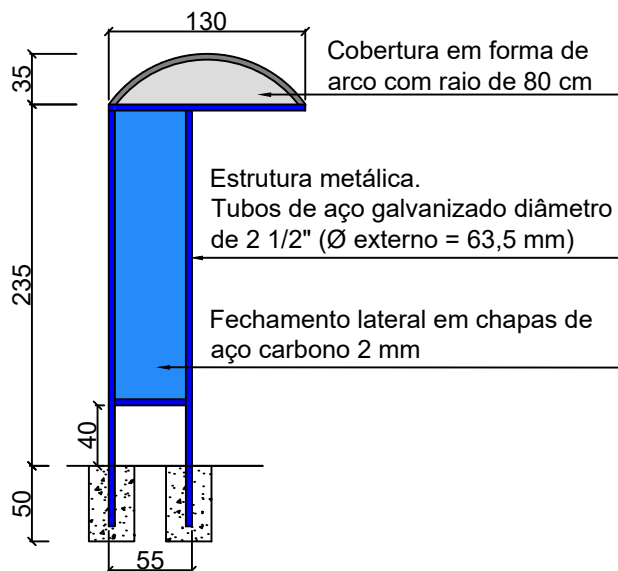

**CORTE 2 - LATERAL**

Medidas em centímetros.

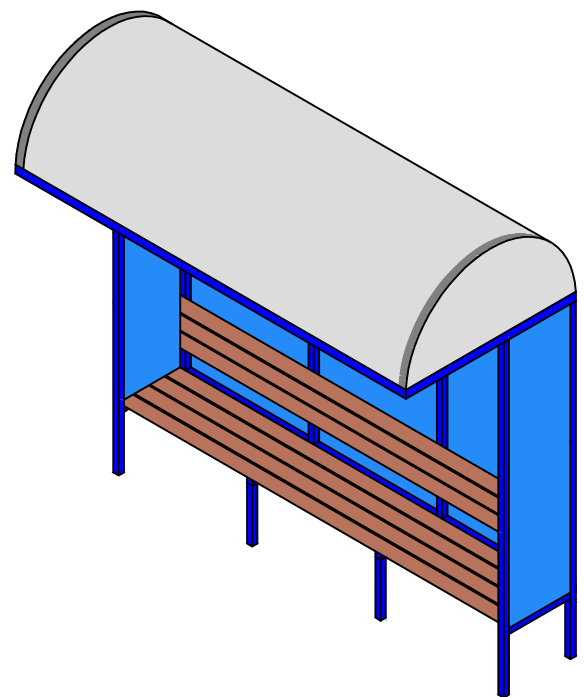

**PERSPECTIVA  
DESENHO ESQUEMÁTICO**



**PREFEITURA MUNICIPAL DE PINHEIRO PRETO**

TÍTULO

**PONTO DE ÔNIBUS**

ESCALA

**1/5**

DATA

**DEZEMBRO/2019**

RESPONSÁVEL TÉCNICA

**DEBORA GANASINI**  
ENGENHEIRA CIVIL  
CREA SC 168017-0

ASSINATURA

\_\_\_\_\_